

GARANTI

För våra produkter lämnas 2 års garanti räknat från försäljningsdatum. Garantin omfattar fabriktions- och materialfel. Skador som orsakats av felaktig montering och skötsel ersättes ej. Garantiersättning enligt svensk praxis kan endast åberopas tillsammans med inköpskvitto varav framgår varutyp, datum och försäljningsställe. Vid eventuell reklamation sändes den felaktiga varan eller i förekommande fall utbytbar defekt detalj tillsammans med kvitto enligt ovan och genom återförsäljarens försorg till: CALIX AB, Box 5026, 630 05 ESKILSTUNA.

GUARANTEE

We grant a 12 months guarantee on the product commencing on the date of purchase. The guarantee applies to faults in material or workmanship. Damage arising from incorrect assembly or improper use are not covered by this guarantee. In the event of a claim under this guarantee, hand in the failing product or part with the original invoice to your Calix dealer. The dealer transmits the product/part to the importer. The guarantee only comes into force if the article, the date and the place of the purchase are specified on the invoice. All other claims are excluded from this guarantee unless our liability is legally mandatory.

Art.no 2200189

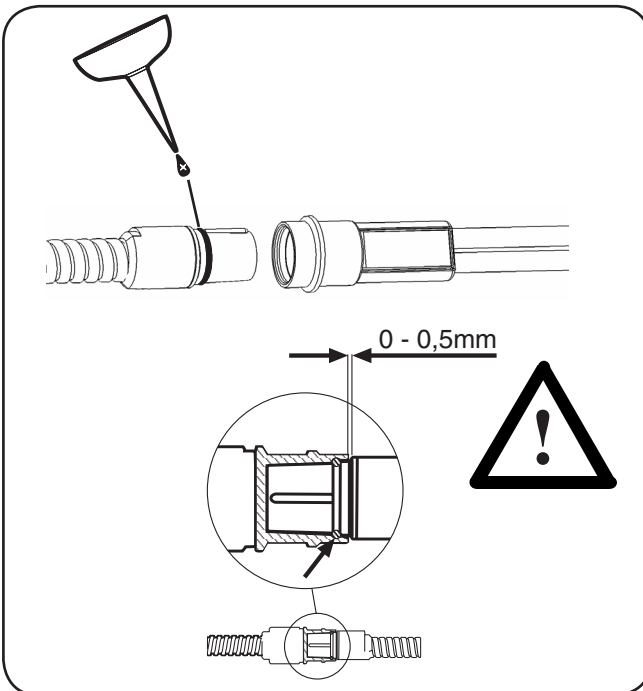
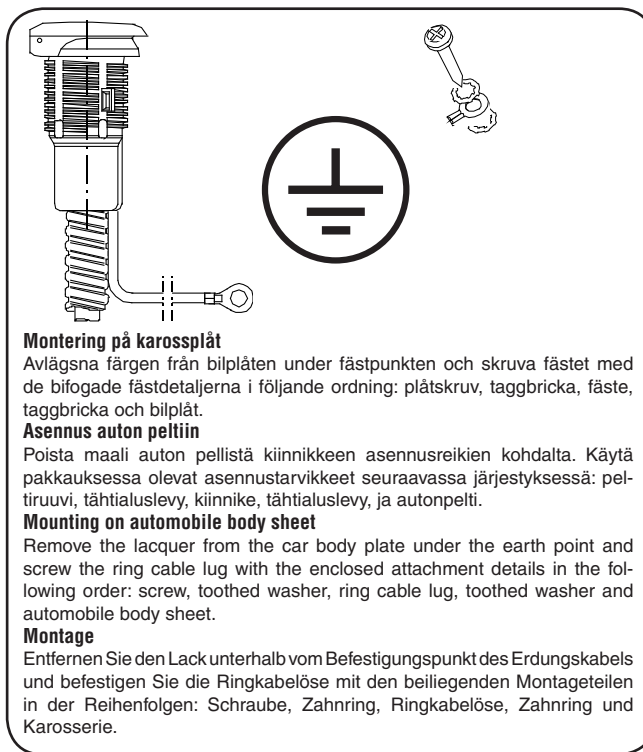

PRODUKT TYP 08.06.24
Calix MK, MS IP46
 250V ~ / 16A

MONTERINGSANVISNING ASENNUSOHJEET EINBAUHNWEISE ASSEMBLY INSTRUCTIONS INSTRUCTIONS DE MONTAGE

MINI-KONTAKT

DECLARATION OF CONFORMITY

according to the
 Low Voltage Directive, 73/23/EEC, the EMC Directive, 89/336/EEC, including amend-
 ments by the CE marking Directive, 93/68/EEC

| | |
|--------------------|------------------|
| Product | Type designation |
| Inlet cable | MK |
| Mains supply cable | MS |

The following harmonised European standards or technical specifications have been applied :

| | | |
|------------------------|------------------------|-------------------|
| Standards | Test reports issued by | Regarding |
| SS 433 07 90 | SEMKO | electrical safety |
| EN 60 335-1 | SEMKO | electrical safety |
| EN 60 309-1 / 2 (1992) | SEMKO | electrical safety |
| CENELEC HD22 | SEMKO | electrical safety |
| CEE 7 | SEMKO | electrical safety |

– The products comply with the LVD safety standards as per above.

We have an internal production control system that ensures compliance between the manufactured products and the technical documentation.

The products is CE marked in -96.

As manufacturer, we declare under our sole responsibility that the equipment follows the provisions of the Directives stated above.

Eskilstuna, June 11, 2008



 Bo Norlin
 President

Calix AB

Box 5026, S-630 05 Eskilstuna, Sweden
 Tel: 016-10 80 00 Fax: 016-13 41 19. E-mail: info@calix.se
 Internet: www.calix.se

Calix

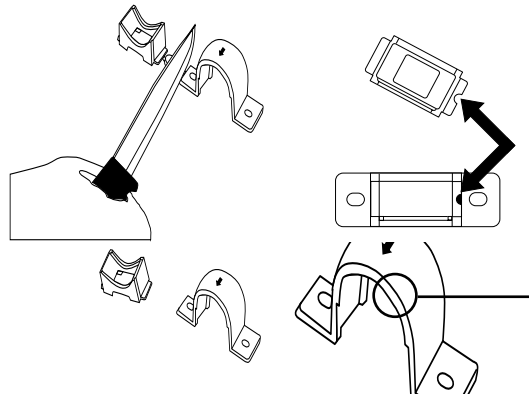
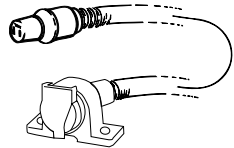
MONTERINGSEXEMPEL
MED HÅLLARE



1.

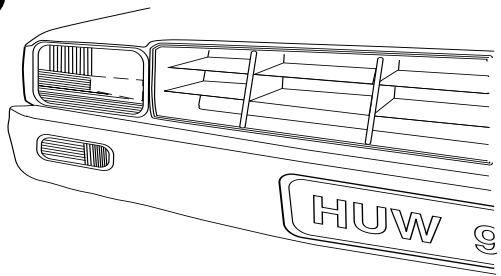

2.

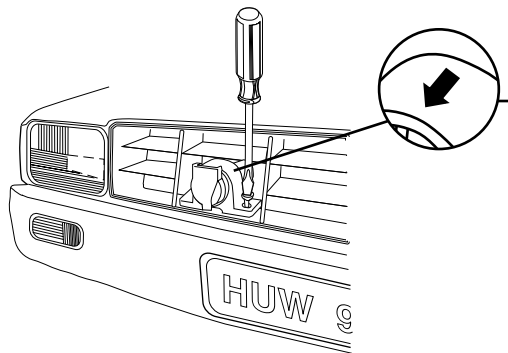

MONTERINGSEXEMPEL
MED EXPANDER

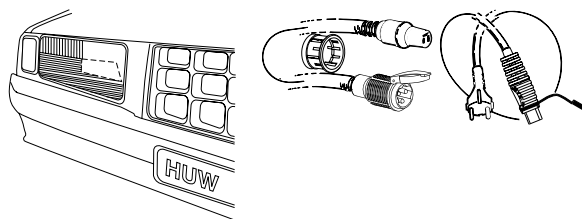

1.

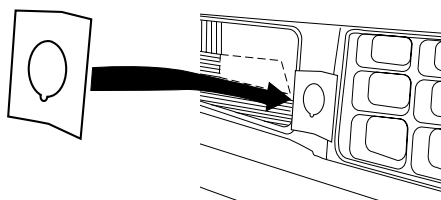

2.

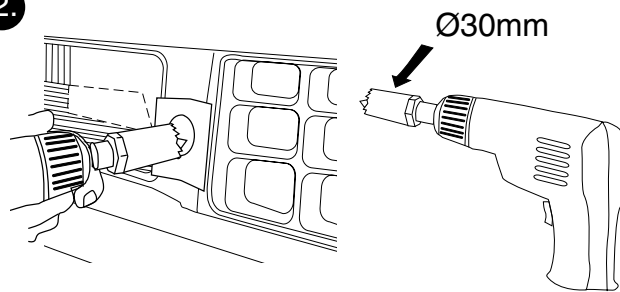

3.

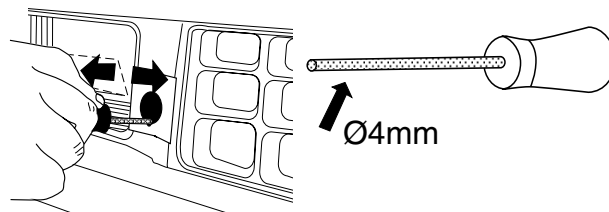

4.

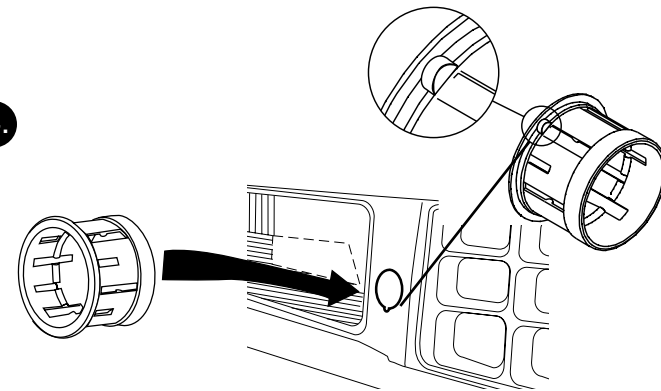

5.

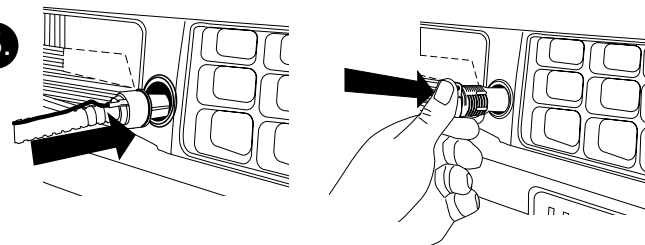

6.

